

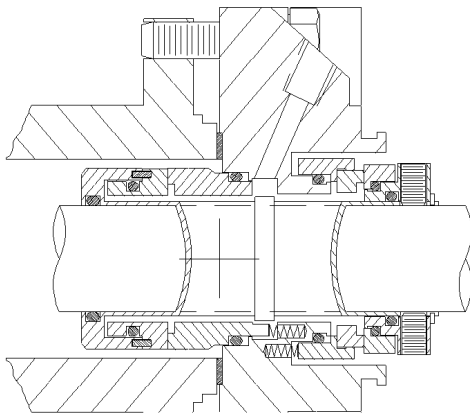

DELTA DOUBLE CARTRIDGE SEAL FOR PUMPS WITH NARROW CROSS SECTION

Designed especially to fit Frame 1 ANSI pumps with 0.312 Inch cross section packing space without modification. Double-balanced stationary design with options for 2 piece stationary and corrosive service metal insert.

STYLE 3205



Technical Features

Self-venting, bi-directional barrier fluid connections accommodate shaft rotations in either direction on horizontal and vertically mounted equipment.

Double balanced, stationary design can be operated in two modes. In double mode the barrier fluid pressure higher is than stuffing box pressure. In tandem mode the barrier fluid pressure is lower than stuffing box pressure and can accommodate pressure reversals at the inboard faces.

Cool running double cartridge design combines large internal clearances, optimal inboard and outboard face widths, and centrally located flush ports. These features maximize the circumferential flow around the seal faces, resulting in more efficient cooling and extended seal life.

Optional special metal insert provides a cost effective alternative for corrosive service. This design variation uses a special metal insert (Titanium, Hastelloy "B", "C") for the process wetted surface in a standard 316 SS gland.

Rotary inboard faces stabilized under compression are flexibly mounted utilizing o-rings for their shock and vibration absorption qualities. This eliminates premature fractures in the faces under thermal and mechanical shock that can cause catastrophic failures in other designs with faces under tension.

Balanced stationary cartridge design utilizes all static o-rings, which eliminates damage to the pump shaft/sleeve or seal normally caused by rotary pusher component or pusher cartridge type seals, allowing use of solid pump shafts that minimize deflection.

Interchangeable stationary faces enable application customization, resulting in stable, secure sealing, accommodating the widest range of operating conditions and applications in industry. Choose from:

- Monolithic, one-piece face designs that provide unparalleled face stability under fluctuating system operating conditions, resulting in superior emission control capabilities.
- Two piece face designs that assure optimum seal performance for the most challenging, demanding environments where one piece face construction is vulnerable to premature failure.

Positive hold, metal centering clips center the seal in both the axial and radial directions.

Choose from spare parts kits for field repair or the optional factory repair program. State of the art, easy-to-install design uses the least number of components, simplifying field repair, resulting in low life cycle costs.

All seals are pressure tested at the factory assuring 100% startup sealability.

Optional Features and Ordering Information:

- 2 piece stationary face
- Special metal insert: order seal model S205

Application Data

Shaft speed: To 3600 RPM

Pressure: Vacuum to 400 PSI

Temperature: See O-ring limitations

Materials

Metal Parts: 316SS, Alloy 20, Hastelloy "C", Titanium

Springs: Hastelloy "C"

Faces: Combinations of Carbon, Sintered-Silicon Carbide, and Tungsten Carbide

Elastomers: Viton, EPR, Kalrez, Aflas, Teflon

DIMENSIONAL DATA FOR DELTA SEAL STYLE 3205

FRONT VIEW

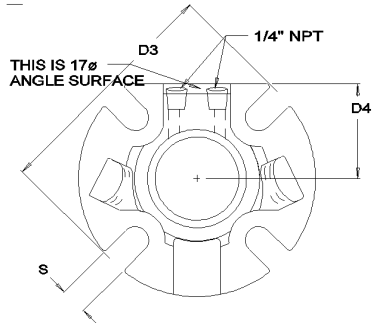

SIDE VIEW

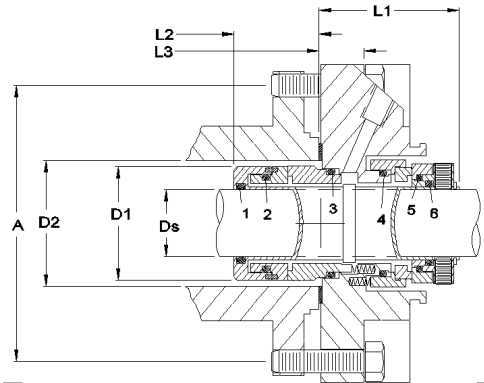

OPTIONAL GLAND FEATURE

Optional exotic metal gland insert for corrosive environments. (Hastelloy "C", "B", Titanium, etc.)

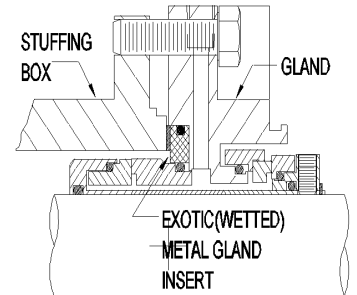

DS Seal Size	D1 Sleeve OD	D2 Min	D2 Max	D3 Gland OD	D4 Gland Flat	A				S Slot Width	L1 Outside Length	L2 Inside Length	L3 Gland Length
						Min. Bolt Circle by Stud Size							
						3/8"	1/2"	5/8"	3/4"				

Distributed By:

(Phone)
(Fax)

© 2004 Delta Mechanical Seals. All rights reserved. Patent Pending



Manufactured By:

Delta Mechanical Seals
44 Propper Lane
Fall River, MA 02720
(508) 324-4032 (Phone)
(508) 324-4339 (Fax)