



DELTA SINGLE CARTRIDGE SEAL WITH API DESIGN

Single cartridge seal design per API 610 7th edition. Flush connections standard, confined gland gasket, gland pilot register, floating throttle bushing, and narrow face technology

STYLE 3610



Technical Features

API 610 Design features include confined gland gasket, gland pilot register, floating throttle bushing, narrow face technology.

Tangential flush connections positioned over the seal faces utilize the largest thru hole diameter available, supplying over 4 times the volume of straight drilled flush holes, providing maximum cooling and cleaning of seal faces maximizing seal life.

Rotary inboard faces stabilized under compression are flexibly mounted utilizing o-rings for their shock and vibration absorption qualities. This eliminates premature fractures in the faces under thermal and mechanical shock that can cause catastrophic failures in other designs with faces under tension.

Balanced stationary cartridge design utilizes all static o-rings, which eliminates damage to the pump shaft/sleeve or seal normally caused by rotary pusher component or pusher cartridge type seals, allowing use of solid pump shafts which minimize deflection.

Gland registered to stuffing box by I.D. or O.D. pilot.

Choose from spare parts kits for field repair or the optional factory repair program. State of the art, easy-to-install design uses the least number of components, simplifying field repair, resulting in low life cycle costs.

All seals are pressure tested at the factory assuring 100% sealability during startup.

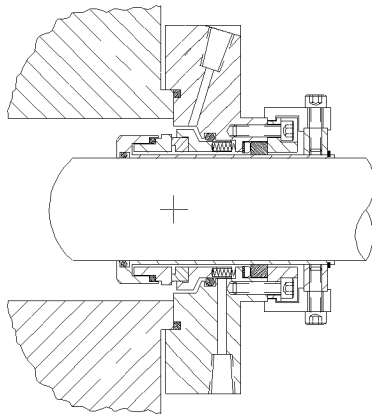

Application Data

Shaft speed: To 3600 RPM

Pressure: Vacuum to 400 PSI

Temperature: See O-ring limitations

Materials

Metal Parts: 316SS

Springs: Hastelloy "C"

Faces: Combinations of Carbon, Sintered-Silicon Carbide, and Tungsten Carbide

Elastomers: Viton, EPR, Kalrez, Aflas, Teflon

DIMENSIONAL DATA FOR DELTA SEAL STYLE 3610

FRONT VIEW

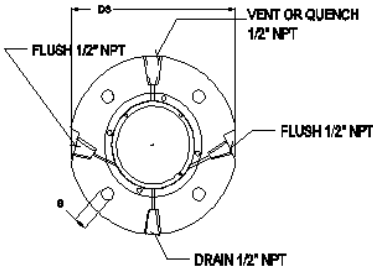

SIDE VIEW

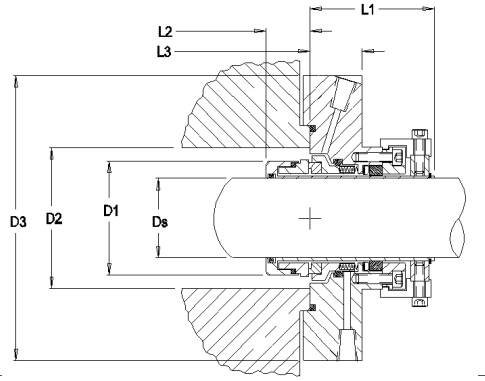

OPTIONAL GLAND FEATURE

DS Seal Size	D1 Sleeve OD	D2 Min	D2 Max	D3 Gland OD	D4 Gland Flat	A Min. Bolt Circle by Stud Size				S Slot Width	L1 Outside Length	L2 Inside Length	L3 Gland Length
						3/8"	1/2"	5/8"	3/4"				

Distributed By:

(Phone)
(Fax)

© 2004 Delta Mechanical Seals. All rights reserved. Patent Pending



Manufactured By:

Delta Mechanical Seals
44 Propper Lane
Fall River, MA 02720
(508) 324-4032 (Phone)
(508) 324-4339 (Fax)