



DELTA DOUBLE CARTRIDGE SEAL WITH PUMPING RING FOR MOYNO® AND TARBY® PUMPS

High efficiency forced circulation pumping ring design. Designed with special gland geometry for progressing cavity pumps.

STYLE 3820



Technical Features

High efficiency pumping design provides 400% increase in flow, providing superior heat removal through the circulated barrier fluid.

Special gland geometry for positive displacement pumps allows use of a standard cartridge seal in place of OEM component seals. The use of cartridge seals simplifies installation and avoids potential damage to shaft and seal components.

Self-venting, bi-directional barrier fluid connections accommodate shaft rotations in either direction on horizontal and vertically mounted equipment.

Double balanced, stationary design can be operated in two modes. In double mode the barrier fluid pressure higher is than stuffing box pressure. In tandem mode the barrier fluid pressure is lower than stuffing box pressure and can accommodate pressure reversals at the inboard faces.

Cool running double cartridge design combines large internal clearances, optimal inboard and outboard face widths, and centrally located flush ports. These features maximize the circumferential flow around the seal faces, resulting in more efficient cooling and extended seal life.

Rotary inboard faces stabilized under compression are flexibly mounted utilizing o-rings for their shock and vibration absorption qualities. This eliminates premature fractures in the faces under thermal and mechanical shock that can cause catastrophic failures in other designs with faces under tension.

Balanced stationary cartridge design utilizes all static o-rings, which eliminates damage to the pump shaft/sleeve or seal normally caused by rotary pusher component or pusher cartridge type seals, allowing use of solid pump shafts that minimize deflection.

Positive hold, metal centering clips center the seal in both the axial and radial directions.

Choose from spare parts kits for field repair or the optional factory repair program. State of the art, easy-to-install design uses the least number of components, simplifying field repair, resulting in low life cycle costs.

All seals are pressure tested at the factory assuring 100% sealability during startup.

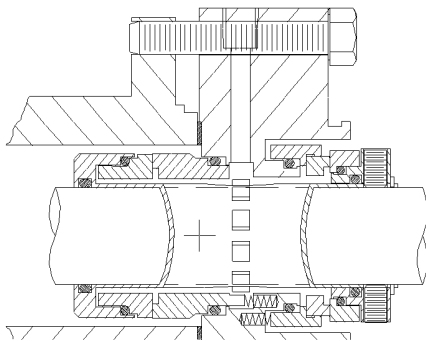

Application Data

Shaft speed: To 3600 RPM

Pressure: Vacuum to 400 PSI

Temperature: See O-ring limitations

Materials

Metal Parts: 316SS, Alloy 20

Springs: Hastelloy "C"

Faces: Combinations of Carbon, Sintered-Silicon Carbide, and Tungsten Carbide

Elastomers: Viton, EPR, Kalrez, Aflas, Teflon

DIMENSIONAL DATA FOR DELTA SEAL STYLE 3820

FRONT VIEW

SIDE VIEW

OPTIONAL GLAND FEATURE

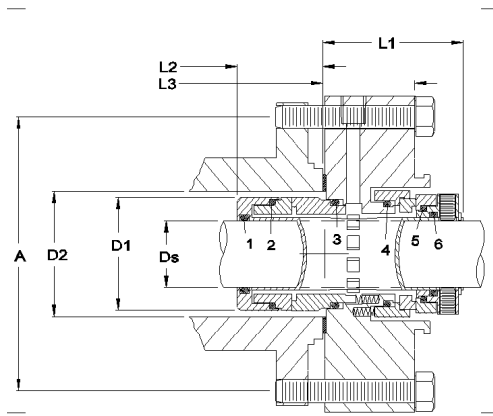
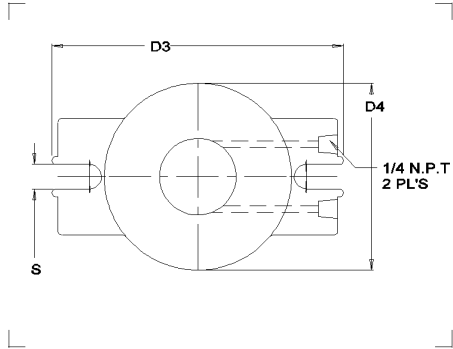

DS Seal Size	D1 Sleeve OD	D2 Min	D2 Max	D3 Gland OD	D4 Gland Flat	A				S Slot Width	L1 Outside Length	L2 Inside Length	L3 Gland Length
						Min. Bolt Circle by Stud Size							
						3/8"	1/2"	5/8"	3/4"				

Distributed By:

(Phone)
(Fax)

© 2004 Delta Mechanical Seals. All rights reserved. Patent Pending



Manufactured By:

Delta Mechanical Seals
44 Propper Lane
Fall River, MA 02720
(508) 324-4032 (Phone)
(508) 324-4339 (Fax)