

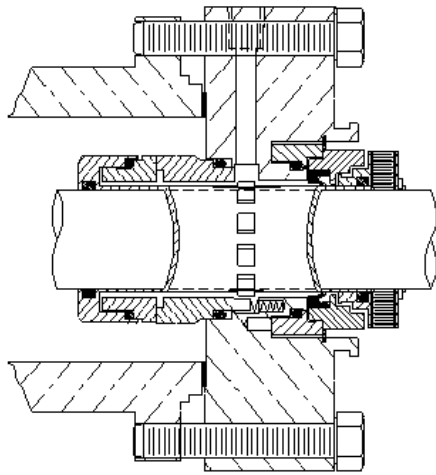

DELTA SINGLE CARTRIDGE SEAL WITH PUMPING RING FOR PUMPS WITH ENLARGED / TAPER BORE IN SEVERE SERVICE APPLICATIONS

STYLE 8021

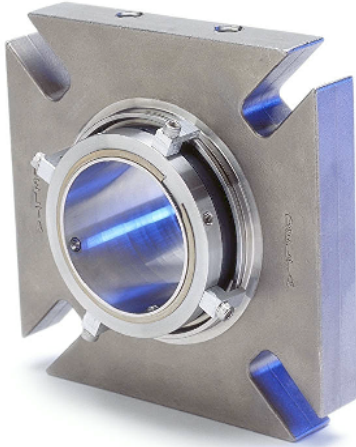

Pumping ring design for large bore / taper bore seal chambers. Optional floating throttle bushing or lip seal provides solution for dissolved and undissolved solids and thermally sensitive fluid applications.

Technical Features

High efficiency pumping design provides 400% increase in flow, providing superior heat removal through the circulated barrier fluid.

Delta's integral throttle bushing or lip seal option provides a quench on the atmospheric side of seal to prevent buildup of particles carried by normal seal weepage of product which may cause hang-up of springs and seal faces. Offers a cost-effective alternative as a replacement to using compression packing, double mechanical seals with auxiliary systems, and dynamically sealed or magnetic drive pumps.

Provides superior, trouble-free performance in abrasive slurries without the use of flush water. Rotating seal component surface geometry is smooth and has no holes, pins or setscrew indentations exposed that could create turbulence causing erosion of the face. Seal faces are positioned deep inside the seal chamber, maximizing heat transfer.

Self-venting, bi-directional barrier/quench fluid connections accommodate shaft rotations in either direction on horizontal and vertically mounted equipment.

Interchangeable stationary faces enable application customization, accommodating the widest range of operating conditions and applications in industry. Monolithic, one-piece designs provide unequalled face stability under fluctuating system operating conditions. Two piece face designs that assure optimum seal performance for the most challenging, demanding environments where one piece face construction is vulnerable to premature failure.

All static o-rings are used throughout, which eliminates damage to the pump shaft/sleeve or seal normally caused by rotary pusher component or pusher cartridge type seals, allowing use of solid pump shafts that minimize deflection.

Optional special metal insert provides a cost effective alternative for corrosive service. This design variation uses a special metal insert (Titanium, Hastelloy "B", "C") for the process wetted surface in a standard 316 SS gland.

Rotary inboard faces stabilized under compression are flexibly mounted utilizing o-rings for their shock and vibration absorption qualities. This eliminates premature fractures in the faces under thermal and mechanical shock that can cause catastrophic failures in other designs with faces under tension.

Stationary springs are mounted in the gland and isolated from the pumped product and are not susceptible to centrifugal force during operation so coil fatigue of the springs is prevented.

Optional Features:

- 2 piece stationary face
 - Exotic Metal Gland insert design
- Select one of the following:
- Floating Throttle Bushing design (Bronze or Carbon)
 - Lip Seal Design

Application Data

Shaft speed: To 3600 RPM

Pressure: Vacuum to 400 PSI

Temperature: See O-ring limitations

Materials

Metal Parts: 316SS, Alloy 20, Hastelloy "C", Titanium

Springs: Hastelloy "C"

Faces: Combinations of Carbon, Sintered-Silicon Carbide, and Tungsten Carbide

Elastomers: Viton, EPR, Kalrez, Aflas, Teflon

DIMENSIONAL DATA FOR DELTA SEAL STYLE 8021

FRONT VIEW

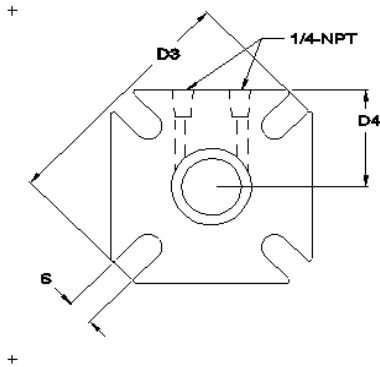

SIDE VIEW

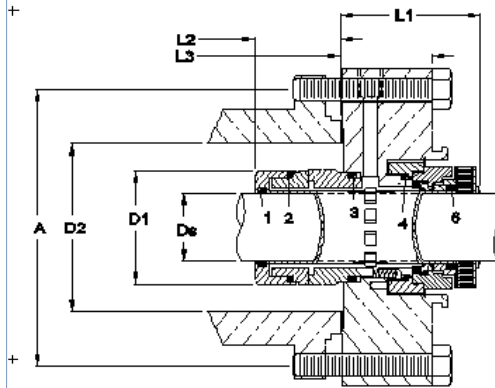

OPTIONAL GLAND FEATURE

Optional exotic metal gland insert for corrosive environments. (Hastelloy "C", "B", Titanium, etc.)

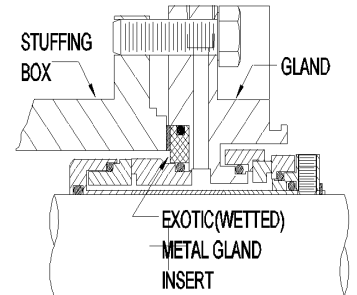

DS Seal Size	D1 Sleeve OD	D2 Min	D2 Max	D3 Gland OD	D4 Gland Flat	A				S Slot Width	L1 Outside Length	L2 Inside Length	L3 Gland Length
						Min. Bolt Circle by Stud Size							
						3/8"	1/2"	5/8"	3/4"				

Distributed By:

(Phone)
(Fax)

© 2004 Delta Mechanical Seals. All rights reserved. Patent Pending



Manufactured By:

Delta Mechanical Seals
44 Probbler Lane
Fall River, MA 02720
(508) 324-4032 (Phone)
(508) 324-4339 (Fax)