



## DELTA SINGLE CARTRIDGE SEAL FOR MOYNO® AND TARBY® PUMPS IN SEVERE SERVICE APPLICATIONS

Optional floating throttle bushing or lip seal design accommodates fluids with dissolved and undissolved solids. Provides solutions for thermal setting products, crystallization, and slurry applications.

### STYLE 8800



### Technical Features

**Special gland geometry** for positive displacement pumps allows use of a standard cartridge seal in place of OEM component seals. The use of cartridge seals simplifies installation and avoids potential damage to shaft and seal components.

**Delta's integral throttle bushing or lip seal** provides a quench on the atmospheric side of seal to prevent buildup of particles carried by normal seal weepage of product which may cause hang-up of springs and seal faces. The 8000 series offers a cost-effective alternative as a replacement to using compression packing, double mechanical seals with auxiliary systems, and dynamically sealed or magnetic drive pumps.

**Optional gland lip seal** provides a secondary containment seal allowing the use of a quench fluid reservoir, stand pipe, or external water flush for outboard side lubrication of seal faces. This configuration offers reduced maintenance and plant water consumption in demanding applications in power, pulp and paper, and chemical processing industries.

**Self-venting, bi-directional barrier/quench fluid connections** accommodate shaft rotations in either direction on horizontal and vertically mounted equipment.

**Two piece face designs** assures optimum seal performance for the most challenging, demanding environments where one piece face construction is vulnerable to premature failure.

**All static o-rings** are used throughout, which eliminates damage to the pump shaft/sleeve or seal normally caused by rotary pusher component or pusher cartridge type seals, allowing use of solid pump shafts that minimize deflection.

**Rotary inboard faces stabilized under compression** are flexibly mounted utilizing o-rings for their shock and vibration absorption qualities. This eliminates premature fractures in the faces under thermal and mechanical shock that can cause catastrophic failures in other designs with faces under tension.

**Positive hold, metal centering clips** center the seal in both the axial and radial directions.

**Stationary springs are mounted in the gland** and are completely isolated from the pumped product and are not susceptible to centrifugal force during operation so coil fatigue of the springs is prevented.

### Optional Features:

- Select one of the following
  - Floating Throttle Bushing design (Bronze or Carbon)
  - Lip Seal Design

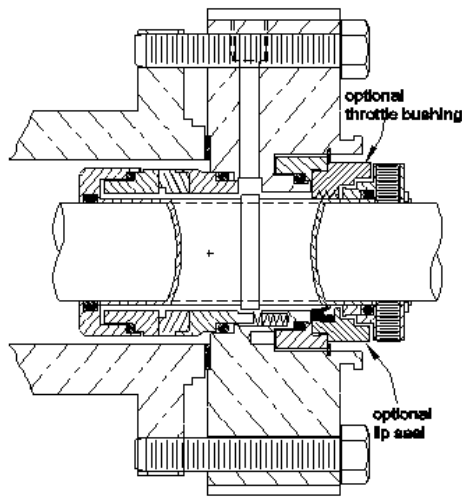

### Application Data

**Shaft speed:** To 3600 RPM

**Pressure:** Vacuum to 400 PSI

**Temperature:** See O-ring limitations

### Materials

**Metal Parts:** 316SS, Alloy 20

**Springs:** Hastelloy "C"

**Faces:** Combinations of Carbon, Sintered-Silicon Carbide, and Tungsten Carbide

**Elastomers:** Viton, EPR, Kalrez, Aflas, Teflon

# DIMENSIONAL DATA FOR DELTA SEAL STYLE 8800

**FRONT VIEW**

**SIDE VIEW**

**OPTIONAL GLAND FEATURE**

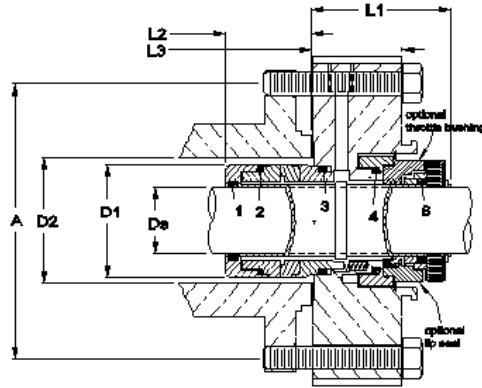

DS Seal Size	D1 Sleeve OD	D2 Min	D2 Max	D3 Gland OD	D4 Gland Flat	A Min. Bolt Circle by Stud Size				S Slot Width	L1 Outside Length	L2 Inside Length	L3 Gland Length
						3/8"	1/2"	5/8"	3/4"				

**Distributed By:**

(Phone)  
(Fax)

© 2004 Delta Mechanical Seals. All rights reserved. Patent Pending



**Manufactured By:**

Delta Mechanical Seals  
44 Propper Lane  
Fall River, MA 02720  
(508) 324-4032 (Phone)  
(508) 324-4339 (Fax)