

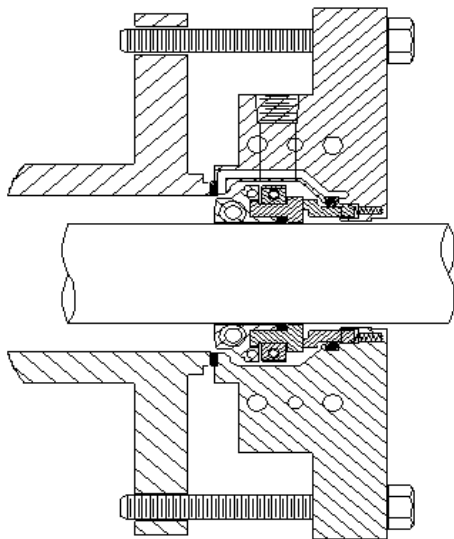

DELTA SPLIT MECHANICAL SEAL FOR LARGE SHAFT SIZES

New patented technology takes split seals into challenging applications. Large size blanced stationary design accomodates shaft sizes from 5.5 inches to 11.250 inches.

STYLE 95LS



Technical Features

Rigidly mounted rotary face design accommodates the broadest range of demanding applications of any split seals available today! The patented two-piece holder securely mounts rotary seal faces under compression eliminating face damage common to flexibly mounted faces.

Automatic seal face alignment simplifies installation and protects face joints from damage. The result is reduced leakage and improved performance.

Advanced, split hard face technology eliminates face breakage and provides a cost effective solution for slurry applications. The use of split tungsten carbide is a first in the industry.

Installation is fast and easy with only two major components. The gland and rotary unit come preassembled. The gland has all components, including the stationary seal face preinstalled. The rotary unit comes with all components preassembled, including seal face halves and o-rings.

No glues or adhesives required for installation eliminating time consuming, error prone procedures that contribute to seal leakage on startup. Only two elastomers (o-rings) are used in the seal design, minimizing leak paths.

High-flow robust gland with large internal clearances provides maximum flow of liquid, moving solids away from seal faces while providing superior cooling. Heavy-duty castings eliminate distortion related failures due to excessive bolt tightening.

Extended seal life with balanced stationary design that results in low frictional heat being generated.

Wide range of applications includes standard ANSI pumps, non-ANSI paper stock and slurry pumps, vertical turbine pumps, between bearing split case pumps, and mixer/agitators.

Special bolting plate adapters or box face adaptors are available for unusual bolting or box dimensions.

Split seal is mounted outside the box eliminating the need to replace worn packing sleeves.

On typical centrifugal pumps, seal design accommodates .002 shaft run out per inch of shaft diameter and .005 axial shaft movement (end play).

On low speed equipment, typically mixers and agitators, the seal design accommodates shaft run out of .062 for seal sizes up to 2.625 and run out of .100 for sizes 2.750 - 5.250. The design accommodates axial shaft movement (end play) up to .015".

Choose from spare parts kits for field repair or the optional factory repair program. State of the art, easy-to-install design uses the least number of components, simplifying field repair, resulting in low life cycle costs.

Application Data

Shaft speed: Sizes 5.500" to 11.250" up to 875 RPM,

Pressure: Vacuum to 100 PSI

Temperature: 250 degree F

Materials

Metal Parts: 316SS

Springs: Hastelloy "C"

Faces: Carbon/Silicon Carbide, Silicon Carbide/Silicon Carbide, Tungsten Carbide/Silicon Carbide

Elastomers: Viton, EPR

DIMENSIONAL DATA FOR DELTA SEAL STYLE 95LS

FRONT VIEW

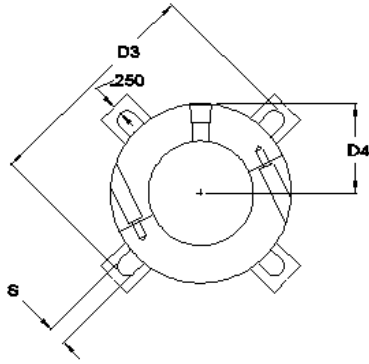

SIDE VIEW

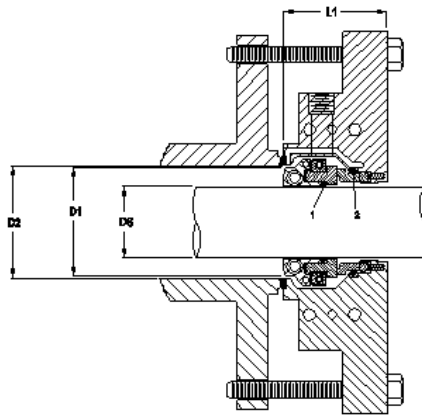

OPTIONAL GLAND FEATURE

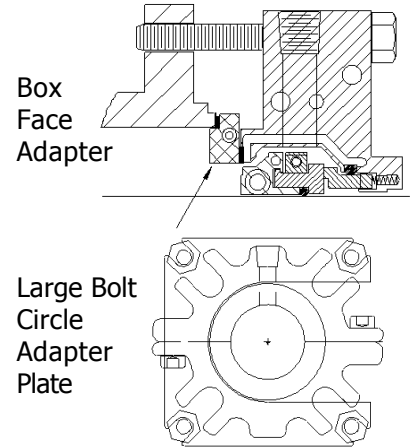

DS Seal Size	D2 Max	D3 Gland OD	A Min. Bolt Circle by Stud Size				S Slot Width	L1 Outside Length
			3/8"	1/2"	5/8"	3/4"		

Distributed By:

(Phone)
(Fax)

© 2004 Delta Mechanical Seals. All rights reserved. Protected under US and International Patents

Manufactured By:



Delta Mechanical Seals
44 Propper Lane
Fall River, MA 02720
(508) 324-4032 (Phone)
(508) 324-4339 (Fax)