

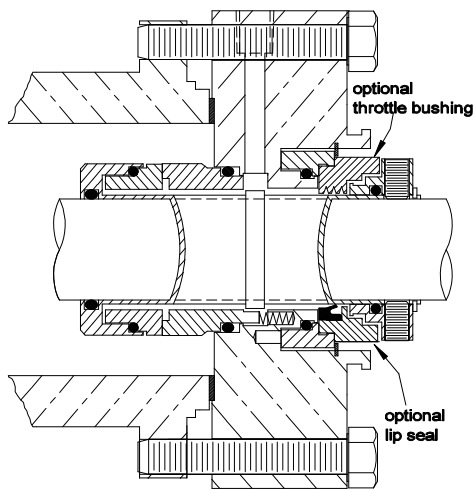

## DELTA SINGLE CARTRIDGE SEAL FOR PUMPS WITH ENLARGED / TAPER BORE IN SEVERE SERVICE APPLICATIONS

Optional floating throttle bushing or lip seal design accommodates fluids with dissolved and undissolved solids. Provides solutions for thermal setting products, crystallization, and slurry applications.

### STYLE 8001

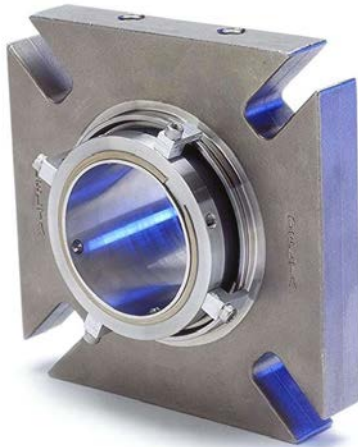

### Technical Features

**Delta's integral throttle bushing or lip seal** provides a quench on the atmospheric side of seal to prevent buildup of particles carried by normal seal weepage of product which may cause hang-up of springs and seal faces. Offers a cost-effective alternative as a replacement to using compression packing, double mechanical seals with auxiliary systems, and dynamically sealed or magnetic drive pumps.

**Provides superior, trouble-free performance** in abrasive slurries without the use of flush water. Rotating seal component surface geometry is smooth and has no holes, pins or setscrew indentations exposed that could create turbulence causing erosion of the face. Seal faces are positioned deep inside the seal chamber, maximizing heat transfer.

**Optional gland lip seal** provides a secondary containment seal allowing the use of a quench fluid reservoir, stand pipe, or external water flush for outboard side lubrication of seal faces. This configuration offers reduced maintenance and plant water consumption in demanding applications in power, pulp and paper, and chemical processing industries.

**Self-venting, bi-directional barrier/quench fluid connections** accommodate shaft rotations in either direction on horizontal and vertically mounted equipment.

**Interchangeable stationary faces enable application customization**, accommodating the widest range of operating conditions and applications in industry. Monolithic, one-piece designs provide unequalled face stability under fluctuating system operating conditions. Two piece face designs that assure optimum seal performance for the most challenging, demanding environments where one piece face construction is vulnerable to premature failure.

**All static o-rings** are used throughout, eliminating damage to the pump shaft/sleeve or seal normally caused by rotary pusher component or pusher cartridge type seals, allowing use of solid pump shafts that minimize deflection.

**Optional special metal insert** provides a cost effective alternative for corrosive service. This design variation uses a special metal insert (Titanium, Hastelloy "B", "C") for the process wetted surface in a standard 316 SS gland.

**Rotary inboard faces stabilized under compression** are flexibly mounted utilizing o-rings for their shock and vibration absorption qualities. This eliminates premature fractures in the faces under thermal and mechanical shock that can cause catastrophic failures in other designs with faces under tension.

**Stationary springs are mounted in the gland** and isolated from the pumped product and are not susceptible to centrifugal force during operation so coil fatigue of the springs is prevented.

### Optional Features:

- 2 piece stationary face
  - Exotic Metal Gland insert design
- Select one of the following:
- Floating Throttle Bushing design (Bronze or Carbon)
  - Lip Seal Design

### Application Data

**Shaft speed:** To 3600 RPM

**Pressure:** Vacuum to 400 PSI

**Temperature:** See O-ring limitations

### Materials

**Metal Parts:** 316SS, Alloy 20, Hastelloy "C", Titanium

**Springs:** Hastelloy "C"

**Faces:** Combinations of Carbon, Sintered-Silicon Carbide, and Tungsten Carbide

**Elastomers:** Viton, EPR, Kalrez, Aflas, Teflon

# METRIC DIMENSIONAL DATA FOR DELTA SEAL STYLE 8001

## FRONT VIEW

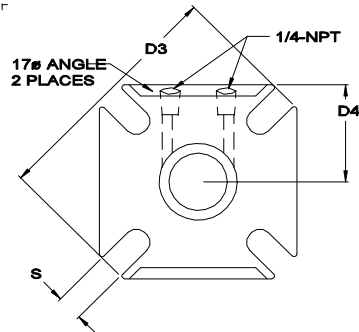

## SIDE VIEW

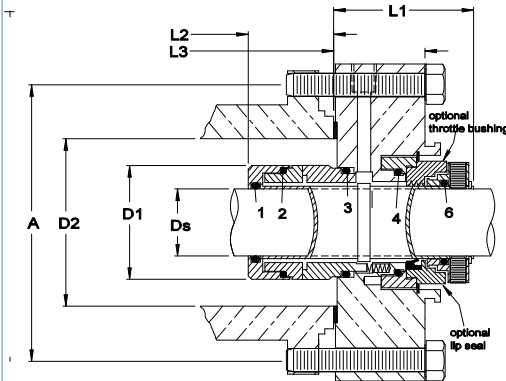

## OPTIONAL GLAND FEATURE

Optional exotic metal gland insert for corrosive environments.  
(Hastelloy "C", "B", Titanium, etc.)

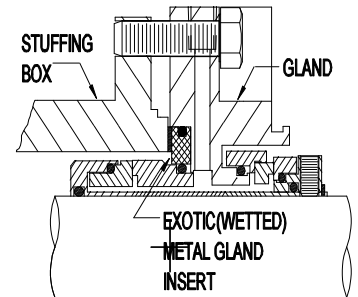

DS Seal Size	D1 Sleeve OD	D2 Min	D2 Max	D3 Gland OD	D4 Gland Flat	A				S Slot Width	L1 Outside Length	L2 Inside Length	L3 Gland Length
						Min. Bolt Circle by Stud Size							
						8mm	10mm	12mm	16mm				
28	45.9	57.1	76.2	111.8	46.1	92	94.1	96.1	100	12.9	54.1	32.3	31.7
33	53	63.5	83.1	134.2	54.3	100	102	104	107.9	11.9	54.1	32.3	31.7
35	53	63.5	83.1	134.2	54.3	100	102	104	107.9	11.9	54.1	32.3	31.7
43	62.4	82.5	104.7	167.2	66.5	119.7	121.7	123.7	127.6	17.2	54.1	32.3	31.7
45	65.6	82.5	104.7	167.2	66.5	119.7	121.7	123.7	127.6	17.2	54.1	32.3	31.7
48	65.6	82.5	104.7	167.2	66.5	119.7	121.7	123.7	127.6	17.2	54.1	32.3	31.7
53	72	88.9	111.3	180.4	69.8	126.9	129	130.9	134.8	17.2	54.1	32.3	31.7
55	75.1	101.6	123.8	207.7	82.1	133.3	135.4	143.7	147.6	20.5	54.1	32.3	31.7
58	78.4	101.6	123.8	207.6	82.1	139.7	141.7	143.7	147.6	17.2	54.1	32.3	31.7
60	78.4	101.6	123.8	207.6	82.1	139.7	141.7	143.7	147.6	17.2	54.1	32.3	31.7
63	81.6	107.9	130.4	199	78.1	147.6	149.7	151.6	155.5	17.2	54.1	32.3	31.7
65	84.8	107.9	127.2	199	78.1	147.5	149.5	151.5	155.4	17.2	54.1	32.3	31.7
68	92.9	114.3	142.8	230.7	88.7	161.8	163.9	165.9	169.8	17.5	58.4	29.4	31.7
70	92.9	114.3	142.8	230.7	88.7	161.8	163.9	165.9	169.8	17.5	58.4	29.4	31.7
75	99.4	114.3	142.8	230.7	88.7	161.8	163.9	165.9	169.8	17.5	58.4	29.4	31.7
90	118.3	142.8	180.9	256.6	99.5	200	202	204	207.9	20.5	58.4	29.4	31.7
95	118.3	142.8	180.9	256.6	99.5	200	202	204	207.9	20.5	58.4	29.4	31.7
110	137.5	174.6	200	299.8	114.8	244.4	246.5	248.5	252.4	20.5	58.4	29.4	31.7
120	143.8	174.6	200	299.8	114.8	244.4	246.5	248.5	252.4	20.5	58.4	29.4	31.7

© 2005 Delta Mechanical Seals. All rights reserved.

Distributed By:

(Phone)  
(Fax)



Manufactured By:

Delta  
44 Probbor Lane  
Fall River, MA 02720  
508-324-4032 (Phone)  
508-324-4339 (Fax)